



DRIVERTRUK 30

Product Code: LTEPEPL1531150

The Liftek DriverTruk 30 electric pallet truck, even more powerful than its predecessors, is the best of an already incredible range.

DRIVERTRUK 30 QUICK SPECS :
Weight = 120 kg / Capacity = 1500 kg :
560 mm x 1150 mm - OTHER FORK SIZES AVAILABLE

KEY FEATURES

- ✓ **Smart Lithium Battery**
- ✓ **Now With Electric Lift**
- ✓ **Newly Designed Handle Head**
- ✓ **Turtle Speed for Upright Handling**
- ✓ **Battery Lock**



CALL US TODAY AND TALK TO OUR TEAM OF EXPERTS

0800 619 0800

www.shshandlingsolutions.com

DRIVERTRUK 30

Product Code: LTEPEPL1531150

Distinguishing mark	1.1	Manufacturer			Liftek
	1.2	Model designation			LTEPEPL1531150
	1.3	Drive			Electric
	1.4	Operator type			Pedestrian
	1.5	Load capacity	Q	kg	1500
	1.6	Load center distance	c	mm	600
Service weight	1.8	Load distance, centre of drive axle to fork	x	mm	950 (880)
	1.9	Wheelbase	y	mm	1190 (1120)
	2.1	Service weight		kg	120
Tyres/chassis	2.2	Axle loading, laden front/rear		kg	480/1140
	2.3	Axle loading, unladen front/rear		kg	90/30
	3.1	Tyre type			Polyurethane
	3.2.1	Tyre size, front		mm	Φ210x70
	3.3.1	Tyre size, rear		mm	Φ80x60 (Φ74x88)
	3.4	Additional wheels (castor wheels)		mm	—
	3.5	Wheels, number front/rear (x=drive wheels)		mm	1x/4 (1x/2)
	3.6.1	Tread width, front	b10	mm	—
	3.7.1	Tread width, rear	b11	mm	410/(535)
	Dimensions	4.4	Lift height	h3	mm
4.9		Height of tiller handle in drive position min./max.	h14	mm	750/1190
4.15		Lowered height	h13	mm	80
4.19		Overall length	l1	mm	1540
4.20		Length to face of forks	l2	mm	400
4.21		Overall width	b1/b2	mm	560 (685)
4.22		Fork dimensions	s/e/l	mm	50x150x1150
4.25		Distance between fork-arms	b5	mm	560 (685)
4.32		Ground clearance, center of wheelbase	m2	mm	30
4.34.1		Aisle width for pallets 1000×1200 crossways	Ast	mm	2145
4.34.2		Aisle width for pallets 800×1200 crossways	Ast	mm	2050
Performance data		4.35	Turning radius	Wa	mm
	5.1	Travel speed, laden/unladen		km/ h	4.5/5.0
	5.2	Lifting speed, laden/unladen		m/s	0.017/0.020
	5.3	Lowering speed, laden/unladen		m/s	0.09/0.06
	5.8	Max. gradeability, laden/unladen		%	6/16
	5.10	Service brake			Electromagnetic
Electric-engine	6.1	Drive motor rating S2 60 min		kW	0.75
	6.2	Lift motor rating at S3 15%		kW	0.7
	6.4	Battery voltage/nominal capacity		V/Ah	24/20
	6.5	Battery weight		kg	7
	Addition data	8.1	Type of drive control		
10.5		Steering design			Mechanical
10.7		Sound pressure level at the driver's ear		dB(A)	<74

If there are improvements of technical parameters or configurations, no further notice will be given. The diagram shown may contain non-standard configurations.

CALL US TODAY AND TALK TO OUR TEAM OF EXPERTS

0800 619 0800

www.shshandlingsolutions.com

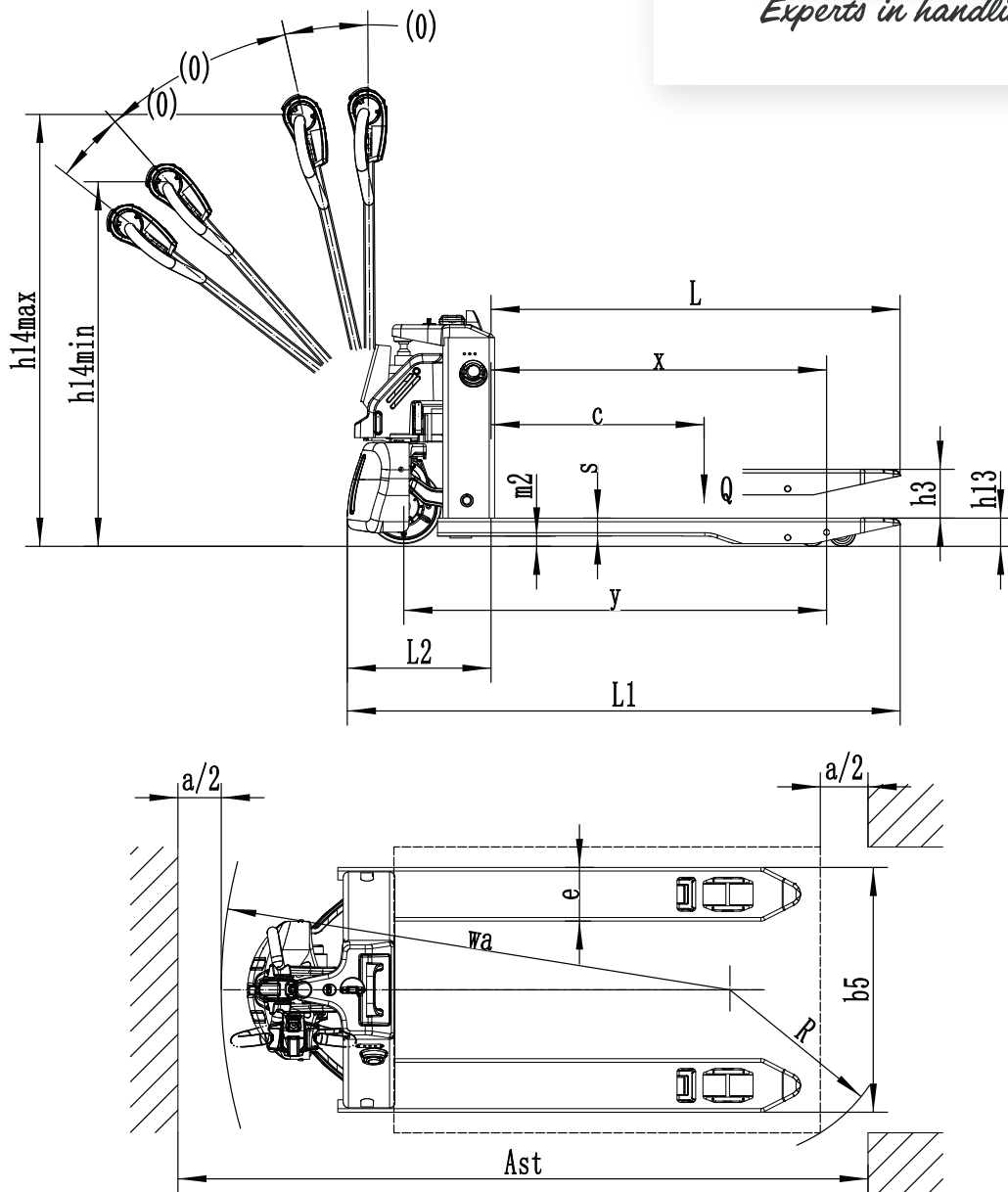

Option:

No.	Optional items	EPL1531
1.1	Fork length	●1150/○900/○1000/○1220/○1500
1.2	Fork width	●560/○685
1.3	Fork lowered height	●80
2.1	Load wheel type	●Double/○Single
2.2	Load wheel material	●PU
2.3	Drive wheel material	●PU/○Trace PU
2.7	Battery capacity	●24V/20Ah
2.8	Charger	●24V-10A External
3.3	Castor wheels	○
3.12	Hummer	●
3.16	Vertical handler working	●

Note: ●Standard ○ Optional - Inconformity

CALL US TODAY AND TALK TO OUR TEAM OF EXPERTS

0800 619 0800

www.shshandlingsolutions.com