

LIFTEK

DRIVERTRUCK30



ELECTRIC
PALLET TRUCK

1500 KG

PRODUCT CODE

LTEPEPL1531150



- Smart Lithium Battery
- Now With Electric Lift
- Newly Designed Handle Head Turtle
- Speed for Upright Handling Battery
- Lock

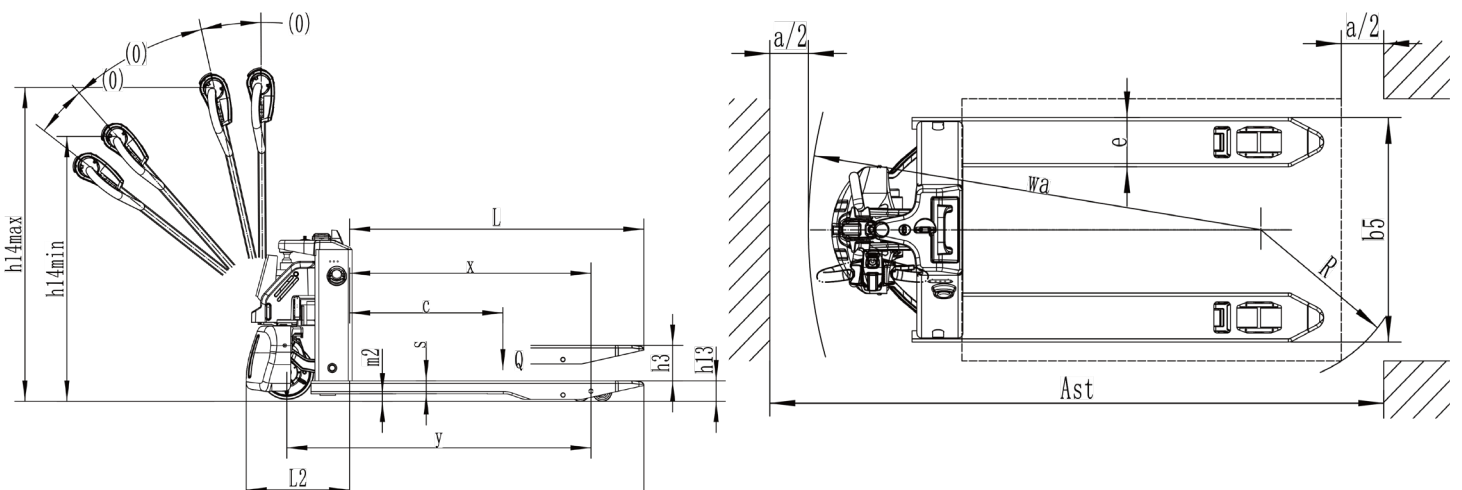

SEE TABLE OVER FOR IMAGE DATA



0800 619 0800
SALES@SHS-HANDLING.COM

SHSHANDLING
SOLUTIONS
.COM

SHS HANDLING SOLUTIONS LTD, ELEVATION HOUSE, UNIT G1-G3, BOROUGH ROAD, BUCKINGHAM INDUSTRIAL ESTATE, BRACKLEY, NN13 7BE

MANUFACTURER'S DATA AND DESIGN CHARACTERISTICS

| Characteristics | | |
|--|----------|-----------------------|
| Manufacturer | | LIFTEK |
| Model | | DriverTruck 30 |
| Type of Operation | | Pedestrian |
| Load Capacity | Q(kg) | 1500 |
| Lift Height | h3(mm) | 115 |
| Service Weight with Battery | kg | 120 |
| Load Centre | c(mm) | 600 |
| Axel Centre to fork face | Ximm | 950 (880) |
| Wheel Base | y(mm) | 1190 (1120) |
| Wheel | | |
| Wheels Type | | Polyurethane |
| Driving Wheels Size | Φx w(mm) | Φ 210x70 |
| Loading Wheels Size | Φx w(mm) | Φ 80x60 |
| Wheels, Number Front/Rear (x=driven) | | 1x/4 (1x/2) |
| Track Width, Rear, Loading Side | b11(mm) | 410/535 |
| Dimensions | | |
| Overall Length | l1mm | 1540 |
| Length to Fork Face | l2(mm) | 400 |
| Overall Width | b1(mm) | 560/685 |
| Fork Dimensions | s/el(mm) | 50/150/1150 |
| Width of Fork | b5(mm) | 560/685 |
| Lower Height | h13(mm) | 80 |
| Min. Ground Clearance | m2(mm) | 30 |
| Height Drawbar in Driving Position min. /max. | h14(mm) | 720/1090 |
| Aisle Width with Pallet 1000 x 1200 across forks | Ast(mm) | 2145 |
| Aisle Width with Pallet 800 x 1200 along forks | Astimm | 2050 |
| Min. Turning Radius | Wa(mm) | 1330 |
| Performance | | |
| Travel Speed, with/without load | km/h | 4.5/5.0 |
| Max. Gradeability laden/unladen | (%) | 6/16 |
| Service Brake Type | | Electromagnetic Brake |
| Drive and Battery | | |
| Drive motor, output s2 60 min. | kW | 0.75 |
| Lift Motor rating at s3 15% | kW | 0.7 |
| Battery According to din 43531/35/36 a,b,c, no | | no |
| Batter Voltage/Rated Capacity | V/Ah | 24/20 |
| Battery Weight (± 5%) | kg | 7 |
| Others | | |
| Type of Drive Control | | DC |
| Sound Pressure Level at Driver's Ear | dB(A) | ≤74 |
| Steering Type | | Mechanical Steering |

AT SHS, WE HELP COMPANIES MOVE GOODS SAFELY AND EFFICIENTLY BY DESIGNING, SUPPLYING, AND MAINTAINING MATERIALS HANDLING EQUIPMENT.