

LIFTEK

ELECTRIC STACKER



COUNTER-BALANCE
STACKER

1000 KG

PRODUCT CODE
ES10-10CA



- ✓ Safe hydraulic system design prevents mast from falling down abruptly when hydraulic pipeline cuts off
- ✓ Emergency reverse belly button protects the operator from getting hurt.
- ✓ Adjustable forks, suitable for complicated pallets or cargos.
- ✓ Tilting as standard configuration, make operation easier.
- ✓ AC traction motor, maintenance free.
- ✓ Control system allows easy trouble-shooting.

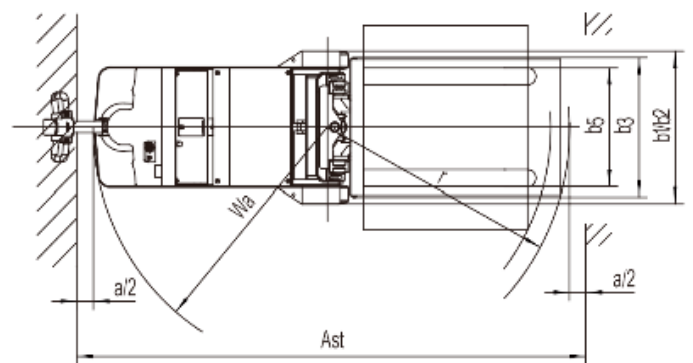
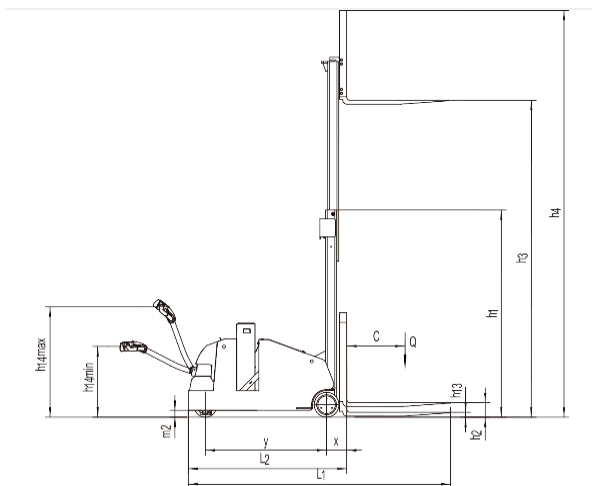

SEE TABLE OVER FOR IMAGE DATA



0800 619 0800
SALES@SHS-HANDLING.COM

SHSHANDLING
SOLUTIONS
.COM

SHS HANDLING SOLUTIONS LTD, ELEVATION HOUSE, UNIT G1-G3,
BOROUGH ROAD, BUCKINGHAM INDUSTRIAL ESTATE, BRACKLEY, NN13 7BE

MANUFACTURER'S DATA AND DESIGN CHARACTERISTICS

Characteristics		
Manufacturer		LIFTEK
Model		ES10-10CA
Type of Operation		Pedestrian
Load Capacity	Q(kg)	1000
Lift Height	h3(mm)	3270
Service Weight with Battery	kg	1950
Load Centre	c(mm)	600
Axel Centre to fork face	Ximm	2087
Wheel Base	y(mm)	1244
Wheel		
Wheels Type		Polyurethane
Driving Wheels Size	Φx w(mm)	Φ 230x75
Loading Wheels Size	Φx w(mm)	Φ 254x102
Wheels, Number Front/Rear (x=driven)		1x,0/2
Track Width, Rear, Loading Side	b11(mm)	787
Dimensions		
Overall Length	l1mm	2703
Length to Fork Face	l2(mm)	1633
Overall Width	b1(mm)	710/900
Fork Dimensions	s/el(mm)	40/100/1070
Width of Fork	b5(mm)	200/760
Lower Height	h13(mm)	60
Min. Ground Clearance	m2(mm)	70
Height Drawbar in Driving Position min. /max.	h14(mm)	715/1200
Aisle Width with Pallet 1000 x 1200 across forks	Ast(mm)	2980
Aisle Width with Pallet 800 x 1200 along forks	Astimm	3095
Min. Turning Radius	Wa(mm)	1425
Performance		
Travel Speed, with/without load	km/h	4.5/5.0
Max. Gradeability laden/unladen	(%)	5.0/8/0
Service Brake Type		Electromagnetic Brake
Drive and Battery		
Drive motor, output s2 60 min.	kW	1.1
Lift Motor rating at s3 15%	kW	2.2
The maximum allowed size battery	mm	680/230/open
Batter Voltage/Rated Capacity	V/Ah	24/224
Battery Weight (± 5%)	kg	160
Charger Specification		
Others		
Type of Drive Control		AC
Sound Pressure Level at Driver's Ear	dB(A)	74
Steering Type		Mechanical Steering

AT SHS, WE HELP COMPANIES MOVE GOODS SAFELY AND EFFICIENTLY BY DESIGNING, SUPPLYING, AND MAINTAINING MATERIALS HANDLING EQUIPMENT.



0800 619 0800
SALES@SHS-HANDLING.COM



SHS HANDLING SOLUTIONS LTD, ELEVATION HOUSE, UNIT G1-G3, BOROUGH ROAD, BUCKINGHAM INDUSTRIAL ESTATE, BRACKLEY, NN13 7BE