

# LIFTEK

POWERTRUK 2000HD

FULLY-ELECTRIC  
PALLET TRUCK

**2000 KG**

PRODUCT CODE

LTEPT20-ET



- ☑ Shock Absorbing Cylinder Frame
- ☑ Super Strength Drive Wheel Cover
- ☑ Extra Durable PU Wheels
- ☑ Industrial Reinforced Battery and Case
- ☑ Multi-Fucntional Operation Handle

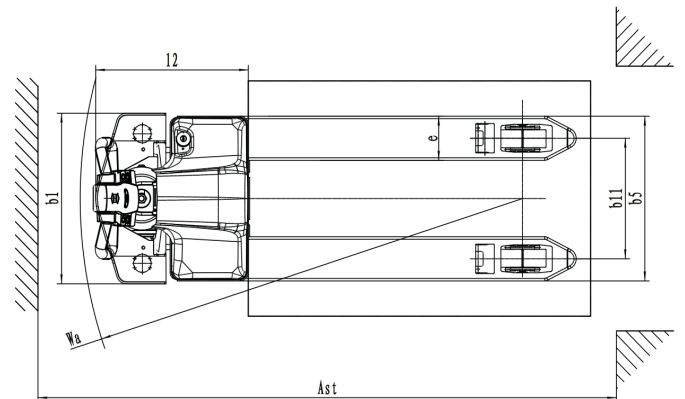
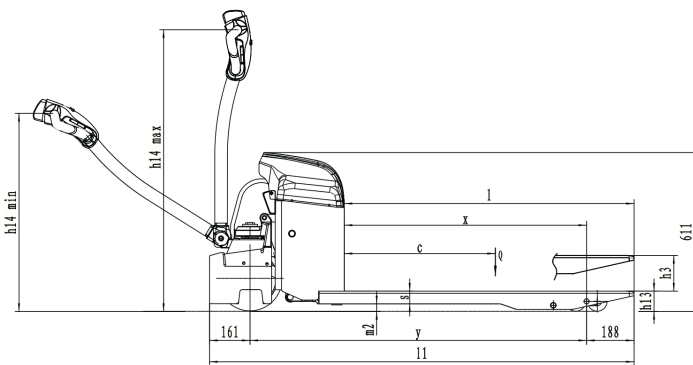

SEE TABLE OVER FOR IMAGE DATA

**SHS**  
HANDLING SOLUTIONS

☎ 0800 619 0800  
✉ SALES@SHS-HANDLING.COM

SHSHANDLING  
SOLUTIONS  
.COM

📍 SHS HANDLING SOLUTIONS LTD, ELEVATION HOUSE, UNIT G1-G3, BOROUGH ROAD, BUCKINGHAM INDUSTRIAL ESTATE, BRACKLEY, NN13 7BE

# MANUFACTURER'S DATA AND DESIGN CHARACTERISTICS

<b>Characteristics</b>		
Manufacturer		LIFTEK
Model		LTEPT20-ET
Type of Operation		Pedestrian
Load Capacity	Q(kg)	2000
Lift Height	h3(mm)	140
Service Weight with Battery	kg	220
Load Centre	c(mm)	600
Axel Centre to fork face	Ximm	874/962
Wheel Base	y(mm)	1248/1336
Controller		CURTIS
<b>Wheel</b>		
Wheels Type		Polyurethane
Driving Wheels Size	Φx w(mm)	Φ 230x74
Loading Wheels Size	Φx w(mm)	Φ 74x30
Wheels, Number Front/Rear (x=driven)		1x2/4
Track Width, Rear, Loading Side	b11(mm)	410 (535)
<b>Dimensions</b>		
Overall Length	l1mm	1685
Length to Fork Face	l2(mm)	535
Overall Width	b1(mm)	560/685
Fork Dimensions	s/el(mm)	50/150/1150
Width of Fork	b5(mm)	560/685
Lower Height	h13(mm)	80
Min. Ground Clearance	m2(mm)	30
Height Drawbar in Driving Position min. /max.	h14(mm)	720/1170
Aisle Width with Pallet 1000 x 1200 across forks	Ast(mm)	2304
Aisle Width with Pallet 800 x 1200 along forks	Astimm	2371
Min. Turning Radius	Wa(mm)	1550
<b>Performance</b>		
Travel Speed, with/without load	km/h	4/5.5
Max. Gradeability laden/unladen	(%)	8/16
Service Brake Type		Electromagnetic Brake
<b>Drive and Battery</b>		
Drive motor, output s2 60 min.	kW	0.75
Lift Motor rating at s3 15%	kW	0.84
Battery According to din 43531/35/36 a,b,c, no		
Batter Voltage/Rated Capacity	V/Ah	12*4/30Ah
Battery Weight (± 5%)	kg	9.5*4
Charger Specification		
<b>Others</b>		
Type of Drive Control		DC
Sound Pressure Level at Driver's Ear	dB(A)	74
Steering Type		Mechanical Steering

AT SHS, WE HELP COMPANIES MOVE GOODS SAFELY AND EFFICIENTLY BY DESIGNING, SUPPLYING, AND MAINTAINING MATERIALS HANDLING EQUIPMENT.