

LIFTEK

VERSATRUCK 1500

FULLY-ELECTRIC
PALLET TRUCK

1500 KG

PRODUCT CODE

LTEPF41150



- ☑ Fully Electric, with Electric Lift and Forwards/Backwards Drive
- ☑ Removable Lithium-Ion Battery
- ☑ Approx. 5.5hrs Constant Usage w/ Single Battery / 11hrs w/ 2 Batteries
- ☑ Only weighs 120kg!
- ☑ 12 Month Warranty as Standard

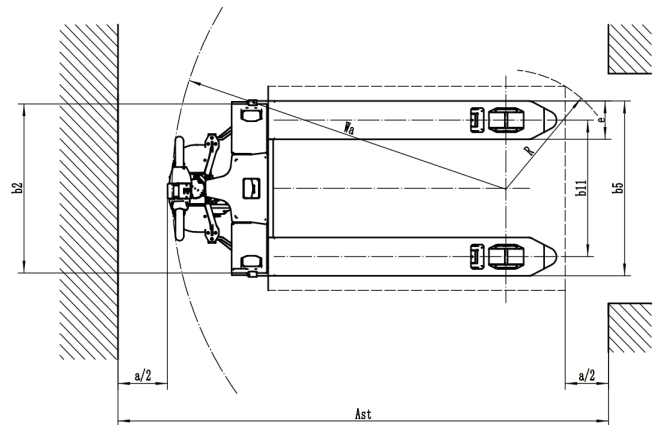
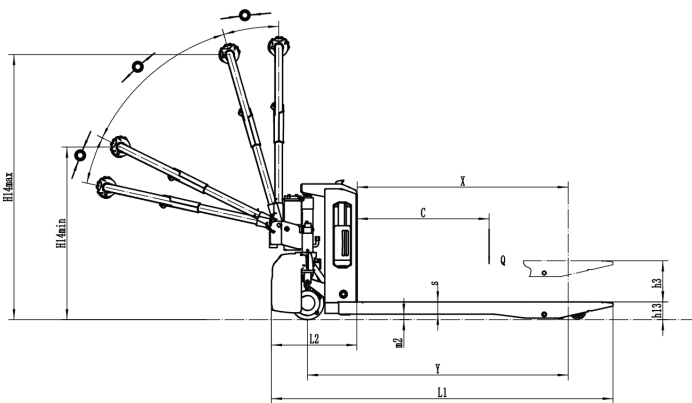

SEE TABLE OVER FOR IMAGE DATA

SHS
HANDLING SOLUTIONS

☎ 0800 619 0800
✉ SALES@SHS-HANDLING.COM

SHSHANDLING
SOLUTIONS
.COM

📍 SHS HANDLING SOLUTIONS LTD, ELEVATION HOUSE, UNIT G1-G3, BOROUGH ROAD, BUCKINGHAM INDUSTRIAL ESTATE, BRACKLEY, NN13 7BE

MANUFACTURER'S DATA AND DESIGN CHARACTERISTICS

Characteristics		
Manufacturer		LIFTEK
Model		LTEPF41150
Type of Operation		Pedestrian
Load Capacity	Q(kg)	1500
Lift Height	h3(mm)	105
Service Weight with Battery	kg	120
Load Centre	c(mm)	600
Axel Centre to fork face	Ximm)	950
Wheel Base	y(mm)	1180
Controller		
Wheel		
Wheels Type		Polyurethane
Driving Wheels Size	Φx w(mm)	Φ 210x70
Loading Wheels Size	Φx w(mm)	Φ 80x60
Wheels, Number Front/Rear (x=driven)		1x2/4
Track Width, Rear, Loading Side	b11(mm)	535/410
Dimensions		
Overall Length	l1mm	1550
Length to Fork Face	l2(mm)	400
Overall Width	b1(mm)	695/560
Fork Dimensions	s/el(mm)	55/150/1150
Width of Fork	b5(mm)	685/560
Lower Height	h13(mm)	82
Min. Ground Clearance	m2(mm)	25
Height Drawbar in Driving Position min. /max.	h14(mm)	750/1190
Aisle Width with Pallet 1000 x 1200 across forks	Ast(mm)	2160
Aisle Width with Pallet 800 x 1200 along forks	Astimm)	2025
Min. Turning Radius	Wa(mm)	1360
Performance		
Travel Speed, with/without load	km/h	4/4.5
Max. Gradeability laden/unladen	(%)	5/16
Service Brake Type		Electromagnetic Brake
Drive and Battery		
Drive motor, output s2 60 min.	kW	0.75
Lift Motor rating at s3 15%	kW	0.5
Battery According to din 43531/35/36 a,b,c, no		-
Batter Voltage/Rated Capacity	V/Ah	24/20
Battery Weight (± 5%)	kg	5
Charger Specification		-
Others		
Type of Drive Control		DC
Sound Pressure Level at Driver's Ear	dB(A)	<74
Steering Type		Mechanical vSteering

AT SHS, WE HELP COMPANIES MOVE GOODS SAFELY AND EFFICIENTLY BY DESIGNING, SUPPLYING, AND MAINTAINING MATERIALS HANDLING EQUIPMENT.